

FIITJEE

Solutions to JEE (Main)-2019

JEE–Main–2019 –Jan–12–First–Shift
PHYSICS, CHEMISTRY & MATHEMATICS

Time Allotted: 3 Hours

Maximum Marks: 360

- Do not open this Test Booklet until you are asked to do so.
- Please read the instructions carefully. You are allotted 5 minutes specifically for this purpose.

Important Instructions:

1. Immediately fill in the particulars on this page of the Test Booklet with *Blue / Black Ball Point Pen*. Use of pencil is strictly prohibited.
2. The Answer Sheet is kept inside this Test Booklet. When you are directed to open the Test Booklet, take out the Answer Sheet and fill in the particulars carefully.
3. The test is of **3 hours** duration.
4. The Test Booklet consists of **90** questions. The maximum marks are **360**.
5. There are **three** parts in the question paper A, B, C consisting of **Physics, Chemistry and Mathematics** having 30 questions in each part of equal weightage. Each question is allotted **4 (four)** marks for correct response.
6. *Candidates will be awarded marks as stated above in instruction No.5 for correct response of each question. One mark will be deducted for indicating incorrect response of each question. No deduction from the total score will be made if no response is indicated for an item in the answer sheet.*
7. There is only one correct response for each question. Filling up more than one response in any question will be treated as wrong response and marks for wrong response will be deducted accordingly as per instruction 6 above.
8. Use **Blue / Black Ball Point Pen only** for writing particulars / marking responses on **Side-1** and **Side-2** of the Answer Sheet. **Use of pencil is strictly prohibited.**
9. No candidate is allowed to carry any textual material, printed or written, bits of papers, pager, mobile phone, any electronic device, etc. except the Admit Card inside the examination hall / room.
10. On completion of the test, the candidate must hand over the Answer Sheet to the Invigilator on duty in the Room / Hall. **However, the candidates are allowed to take away this Test Booklet with them.**
11. **Do not fold or make any stray marks on the Answer Sheet.**

Name of the Candidate (in Capital Letters) : _____

Roll Number : _____

Candidate's Signature: _____

PART –A (PHYSICS)

1. An ideal gas occupies a volume of 2 m^3 at a pressure of $3 \times 10^6 \text{ Pa}$. The energy of the gas is:
 (A) $9 \times 10^6 \text{ J}$ (B) $6 \times 10^4 \text{ J}$
 (C) 10^8 J (D) $3 \times 10^2 \text{ J}$

 2. A travelling harmonic wave is represented by the equation $y(x, t) = 10^{-3} \sin(50t + 2x)$, where x and y are in meter and t is in seconds. Which of the following is a correct statement about the wave?
 (A) The wave is propagating along the negative x -axis with speed 25 ms^{-1} .
 (B) The wave is propagating along the positive x -axis with speed 100 ms^{-1} .
 (C) The wave is propagating along the positive x -axis with speed 25 ms^{-1} .
 (D) The wave is propagating along the negative x -axis with speed 100 ms^{-1} .

 3. An ideal battery of 4 V and resistance R are connected in series in the primary circuit of a potentiometer of length 1 m and resistance 5Ω . The value of R , to give a difference of 5 mV across 10 cm of potentiometer wire, is:
 (A) 490Ω (B) 480Ω
 (C) 395Ω (D) 495Ω

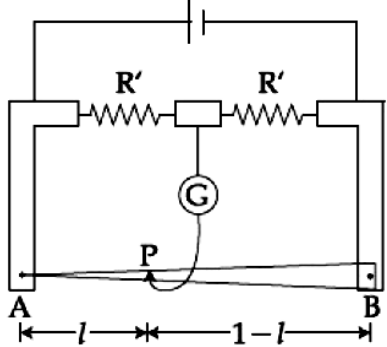
 4. In a meter bridge, the wire of length 1 m has a non-uniform cross-section such that, the variation $\frac{dR}{d\ell}$ of its resistance R with length ℓ is $\frac{dR}{d\ell} \propto \frac{1}{\sqrt{\ell}}$. Two equal resistances are connected as shown in the figure. The galvanometer has zero deflection when the jockey is at point P . What is the length AP ?
 (A) 0.2 m (B) 0.3 m
 (C) 0.25 m (D) 0.35 m
- 
5. A passenger train of length 60 m travels at a speed of 80 km/hr . Another freight train of length 120 m travels at a speed of 30 km/hr . The ratio of times taken by the passenger train to completely cross the freight train when: (i) they are moving in the same direction, and (ii) in the opposite directions is:
 (A) $\frac{11}{5}$ (B) $\frac{5}{2}$
 (C) $\frac{3}{2}$ (D) $\frac{25}{11}$

 6. Two electric bulbs, rated at $(25 \text{ W}, 220 \text{ V})$ and $(100 \text{ W}, 220 \text{ V})$, are connected in series across a 220 V voltage source. If the 25 W and 100 W bulbs draw powers P_1 and P_2 respectively, then:
 (A) $P_1 = 16 \text{ W}, P_2 = 4 \text{ W}$ (B) $P_1 = 16 \text{ W}, P_2 = 9 \text{ W}$
 (C) $P_1 = 9 \text{ W}, P_2 = 16 \text{ W}$ (D) $P_1 = 4 \text{ W}, P_2 = 16 \text{ W}$

 7. A straight rod of length L extends from $x = a$ to $x = L + a$. The gravitational force it exerts on a point mass ' m ' at $x = 0$, if the mass per unit length of the rod is $A + Bx^2$, is given by:
 (A) $Gm \left[A \left(\frac{1}{a+L} - \frac{1}{a} \right) - BL \right]$ (B) $Gm \left[A \left(\frac{1}{a} - \frac{1}{a+L} \right) - BL \right]$
 (C) $Gm \left[A \left(\frac{1}{a+L} - \frac{1}{a} \right) + BL \right]$ (D) $Gm \left[A \left(\frac{1}{a} - \frac{1}{a+L} \right) + BL \right]$

8. What is the position and nature of image formed by lens combination shown in figure? (f_1, f_2 are focal lengths)
- (A) 70 cm from point B at left; virtual
 (B) 40 cm from point B at right; real
 (C) $\frac{20}{3}$ cm from point B at right; real
 (D) 70 cm from point B at right ; real

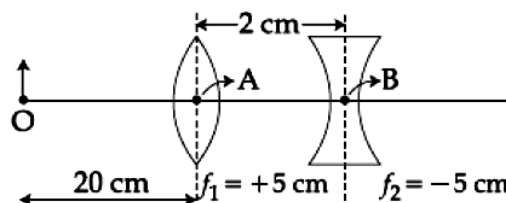

9. A point source of light, S is placed at a distance L in front of the centre of plane mirror of width d which is hanging vertically on a wall. A man walks in front of the mirror along a line parallel to the mirror, at a distance 2L as shown below. The distance over which the man can see the image of the light source in the mirror:
- (A) d
 (B) 2d
 (C) 3d
 (D) $\frac{d}{2}$

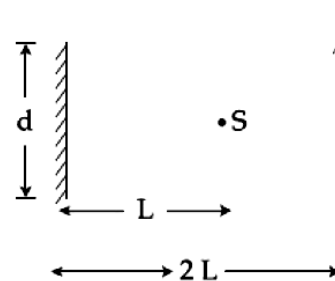

10. A light wave is incident normally on a glass slab of refractive index 1.5. If 4% of light gets reflected and the amplitude of the electric field of the incident light is 30 V/m, then the amplitude of the electric field for the wave propagating in the glass medium will be:
- (A) 30 V/m
 (B) 10 V/m
 (C) 24 V/m
 (D) 6 V/m

11. For the given cyclic process CAB as shown for a gas, the work done is:
- (A) 30 J
 (B) 10 J
 (C) 1 J
 (D) 5 J

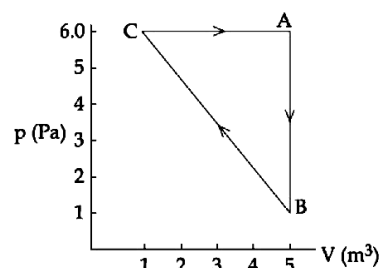

12. Determine the electric dipole moment of the system of three charges, placed on the vertices of an equilateral triangle, as shown in the figure:
- (A) $\sqrt{3} q\ell \frac{\hat{j}-\hat{i}}{\sqrt{2}}$
 (B) $(q\ell) \frac{\hat{i}+\hat{j}}{\sqrt{2}}$
 (C) $2q\ell \hat{j}$
 (D) $-\sqrt{3} q\ell \hat{j}$

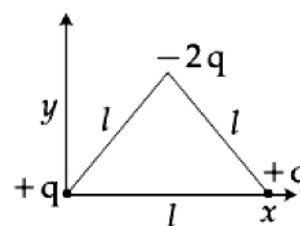

13. The position vector of the centre of mass \vec{r}_{cm} of an asymmetric uniform bar of negligible area of cross-section as shown in figure is:
- (A) $\vec{r}_{cm} = \frac{13}{8}L\hat{x} + \frac{5}{8}L\hat{y}$
 (B) $\vec{r}_{cm} = \frac{5}{8}L\hat{x} + \frac{13}{8}L\hat{y}$
 (C) $\vec{r}_{cm} = \frac{3}{8}L\hat{x} + \frac{11}{8}L\hat{y}$
 (D) $\vec{r}_{cm} = \frac{11}{8}L\hat{x} + \frac{3}{8}L\hat{y}$

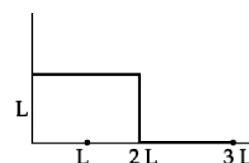

14. A person standing on an open ground hears the sound of a jet aeroplane, coming from north at an angle 60° with ground level. But he finds the aeroplane right vertically above his position. If v is the speed of sound, speed of the plane is:
- (A) $\frac{\sqrt{3}}{2}v$
 (B) $\frac{2v}{\sqrt{3}}$
 (C) v
 (D) $\frac{v}{2}$

15. Two light identical springs of spring constant k are attached horizontally at the two ends of a uniform horizontal rod AB of length l and mass m . The rod is pivoted at its centre 'O' and can rotate freely in horizontal plane. The other ends of the two springs are fixed to rigid supports as shown in figure. The rod is gently pushed through a small angle and released. The frequency of resulting oscillation is:

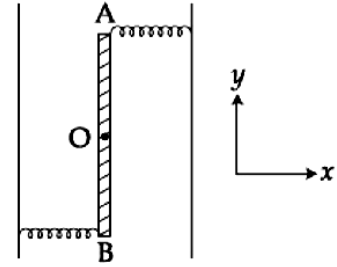

- (A) $\frac{1}{2\pi} \sqrt{\frac{3k}{m}}$ (B) $\frac{1}{2\pi} \sqrt{\frac{2k}{m}}$
 (C) $\frac{1}{2\pi} \sqrt{\frac{6k}{m}}$ (D) $\frac{1}{2\pi} \sqrt{\frac{k}{m}}$

16. A simple pendulum, made of a string of length l and a bob of mass m , is released from a small angle θ_0 . It strikes a block of mass M , kept on a horizontal surface at its lowest point of oscillations, elastically. It bounces back and goes up to an angle θ_1 . Then M is given by:

- (A) $\frac{m}{2} \left(\frac{\theta_0 + \theta_1}{\theta_0 - \theta_1} \right)$ (B) $m \left(\frac{\theta_0 - \theta_1}{\theta_0 + \theta_1} \right)$
 (C) $m \left(\frac{\theta_0 + \theta_1}{\theta_0 - \theta_1} \right)$ (D) $\frac{m}{2} \left(\frac{\theta_0 - \theta_1}{\theta_0 + \theta_1} \right)$

17. A 100 V carrier wave is made to vary between 160 V and 40 V by a modulating signal. What is the modulation index?

- (A) 0.3 (B) 0.5
 (C) 0.6 (D) 0.4

18. A cylinder of radius R is surrounded by a cylindrical shell of inner radius R and outer radius $2R$. The thermal conductivity of the material of the inner cylinder is K_1 and that of the outer cylinder is K_2 . Assuming no loss of heat, the effective thermal conductivity of the system for heat flowing along the length of the cylinder is:

- (A) $\frac{K_1 + K_2}{2}$ (B) $K_1 + K_2$
 (C) $\frac{2K_1 + 3K_2}{5}$ (D) $\frac{K_1 + 3K_2}{4}$

19. The least count of the main scale of a screw gauge is 1 mm. The minimum number of divisions on its circular scale required to measure $5 \mu\text{m}$ diameter of a wire is:

- (A) 50 (B) 200
 (C) 100 (D) 500

20. The output of the given logic circuit is:

- (A) $A\bar{B} + \bar{A}B$
 (B) $AB + \bar{A}\bar{B}$
 (C) $A\bar{B}$
 (D) $\bar{A}B$

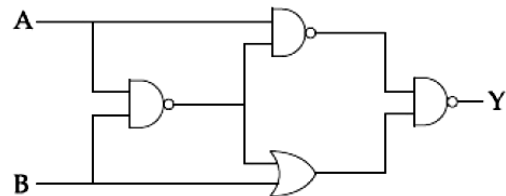

21. As shown in the figure, two infinitely long, identical wires are bent by 90° and placed in such a way that the segments LP and QM are along the x -axis, while segments PS and QN are parallel to the y -axis. If $OP = OQ = 4 \text{ cm}$, and the magnitude of the magnetic field at O is 10^{-4} T , and the two wires carry equal current (see figure), the magnitude of the current in each wire and the direction of the magnetic field at O will be ($\mu_0 = 4\pi \times 10^{-7} \text{ NA}^{-2}$):

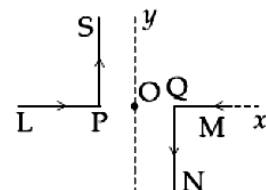

- (A) 20 A, perpendicular out of the page (B) 40 A, perpendicular out of the page
 (C) 20 A, perpendicular into the page (D) 40 A, perpendicular into the page

22. A particle of mass m moves in a circular orbit in a central potential field $U(r) = \frac{1}{2}kr^2$. If Bohr's quantization conditions are applied, radii of possible orbits and energy levels vary with quantum number n as:

- | | |
|---|---|
| (A) $r_n \propto \sqrt{n}, E_n \propto n$ | (B) $r_n \propto \sqrt{n}, E_n \propto \frac{1}{n}$ |
| (C) $r_n \propto n, E_n \propto n$ | (D) $r_n \propto n^2, E_n \propto \frac{1}{n^2}$ |

23. A proton and an α -particle (with their masses in the ratio of 1 : 4 and charges in the ratio of 1:2 are accelerated from rest through a potential difference V . If a uniform magnetic field (B) is set up perpendicular to their velocities, the ratio of the radii $r_p : r_\alpha$ of the circular paths described by them will be:

- | | |
|--------------------|--------------------|
| (A) $1 : \sqrt{2}$ | (B) $1 : 2$ |
| (C) $1 : 3$ | (D) $1 : \sqrt{3}$ |

24. Let the moment of inertia of a hollow cylinder of length 30 cm (inner radius 10 cm and outer radius 20 cm), about its axis be I . The radius of a thin cylinder of the same mass such that its moment of inertia about its axis is also I , is:

- | | |
|-----------|-----------|
| (A) 12 cm | (B) 16 cm |
| (C) 14 cm | (D) 18 cm |

25. In the figure shown, a circuit contains two identical resistors with resistance $R = 5 \Omega$ and an inductance with $L = 2$ mH. An ideal battery of 15 V is connected in the circuit. What will be the current through the battery long after the switch is closed?

- | | |
|-----------|-----------|
| (A) 5.5 A | (B) 7.5 A |
| (C) 3 A | (D) 6 A |

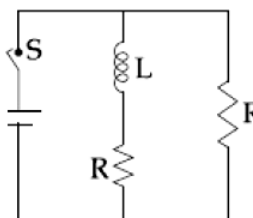

26. In the figure shown, after the switch 'S' is turned from position 'A' to position 'B', the energy dissipated in the circuit in terms of capacitance 'C' and total charge 'Q' is:

- | | |
|---------------------------------|---------------------------------|
| (A) $\frac{1}{8} \frac{Q^2}{C}$ | (B) $\frac{3}{8} \frac{Q^2}{C}$ |
| (C) $\frac{5}{8} \frac{Q^2}{C}$ | (D) $\frac{3}{4} \frac{Q^2}{C}$ |

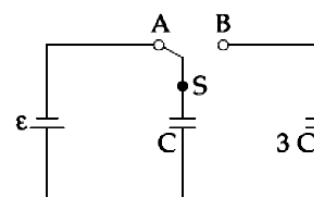

27. A satellite of mass M is in a circular orbit of radius R about the centre of the earth. A meteorite of the same mass, falling towards the earth collides with the satellite completely inelastically. The speeds of the satellite and the meteorite are the same, just before the collision. The subsequent motion of the combined body will be:

- | | |
|--|---|
| (A) such that it escapes to infinity | (B) in an elliptical orbit |
| (C) in the same circular orbit of radius R | (D) in a circular orbit of a different radius |

28. The galvanometer deflection, when key K_1 is closed but K_2 is open, equals θ_0 (see figure). On closing K_2 also and adjusting R_2 to 5Ω , the deflection in galvanometer becomes $\frac{\theta_0}{5}$. The resistance of the galvanometer is, then, given by

[Neglect the internal resistance of battery]:

- | | |
|-----------------|-----------------|
| (A) 5Ω | (B) 22Ω |
| (C) 25Ω | (D) 12Ω |

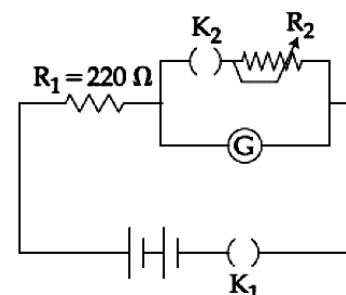

29. A particle A of mass 'm' and charge 'q' is accelerated by a potential difference of 50 V. Another particle B of mass '4 m' and charge 'q' is accelerated by a potential difference of 2500 V. The ratio of de-Broglie wavelength $\frac{\lambda_A}{\lambda_B}$ is close to:
- (A) 10.00 (B) 0.07
(C) 14.14 (D) 4.47

30. There is a uniform spherically symmetric surface charge density at a distance R_0 from the origin. The charge distribution is initially at rest and starts expanding because of mutual repulsion. The figure that represents best the speed $V(R(t))$ of the distribution as a function of its instantaneous radius $R(t)$ is:

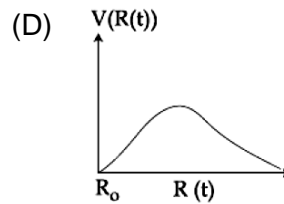
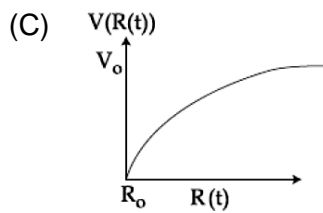
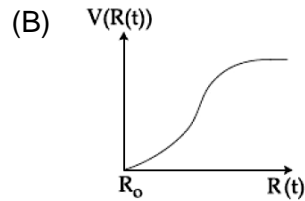
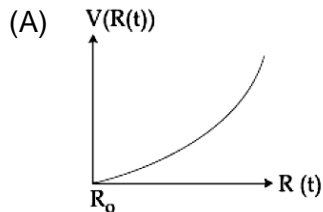

PART – B (CHEMISTRY)

31. In the Hall-heroult process, aluminium is formed at the cathode. The cathode is made out of
 (A) Pure Aluminium (B) Carbon
 (C) Copper (D) Platinum
32. The correct order for acid strength of compounds:
 $\text{CH} \equiv \text{CH}$, $\text{CH}_3 - \text{C} \equiv \text{CH}$, $\text{CH}_2 = \text{CH}_2$
 is as follows:
 (A) $\text{CH} \equiv \text{CH} > \text{CH}_2 = \text{CH}_2 > \text{CH}_3 - \text{C} \equiv \text{CH}$
 (B) $\text{CH}_3 - \text{C} \equiv \text{CH} > \text{CH} \equiv \text{CH} > \text{CH}_2 = \text{CH}_2$
 (C) $\text{CH}_3 - \text{C} \equiv \text{CH} > \text{CH}_2 = \text{CH}_2 > \text{HC} \equiv \text{CH}$
 (D) $\text{HC} \equiv \text{CH} > \text{CH}_3 - \text{C} \equiv \text{CH} > \text{CH}_2 = \text{CH}_2$
33. In a chemical reaction $\text{A} + 2\text{B} \xrightleftharpoons{K} 2\text{C} + \text{D}$, the initial concentration of B was 1.5 times of A but the equilibrium concentrations of A and B were found to be equal. The equilibrium constant(K) for the aforesaid chemical reaction is
 (A) 4 (B) 16
 (C) 1/4 (D) 1
34. Given
 Gas: H_2 CH_4 CO_2 SO_2
 Critical: 33 190 304 630
 Temp/K
 On the basis of data given, predict which of the following gases shows least adsorption on a definite amount of charcoal
 (A) SO_2 (B) CH_4
 (C) CO_2 (D) H_2
35. $\text{Mn}_2(\text{CO})_{10}$ is an organometallic compound due to the presence of
 (A) Mn – C bond (B) Mn – Mn bond
 (C) Mn – O bond (D) C – O bond

36. The major product of the following reaction is:

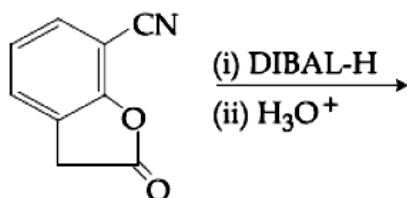

- (A)
- (B)
- (C)
- (D)

37. A metal on combustion in excess air forms X, X upon hydrolysis with water yields H_2O_2 and O_2 along with another product. The metal is:
 (A) Na (B) Rb
 (C) Mg (D) Li
38. The molecules that has minimum/no role in the formation of photochemical smog is:
 (A) N_2 (B) $CH_2 = O$
 (C) O_3 (D) NO
39. The pair of metal ions that can give a spin-only magnetic moment of 3.9 BM for the complex $[M(H_2O)_6]Cl_2$ is
 (A) V^{2+} and Co^{2+} (B) V^{2+} and Fe^{2+}
 (C) Co^{2+} and Fe^{2+} (D) Cr^{2+} and Mn^{2+}

40. For a diatomic ideal gas in a closed system, which of the following plots does not correctly describe the relation between various thermodynamic quantities?

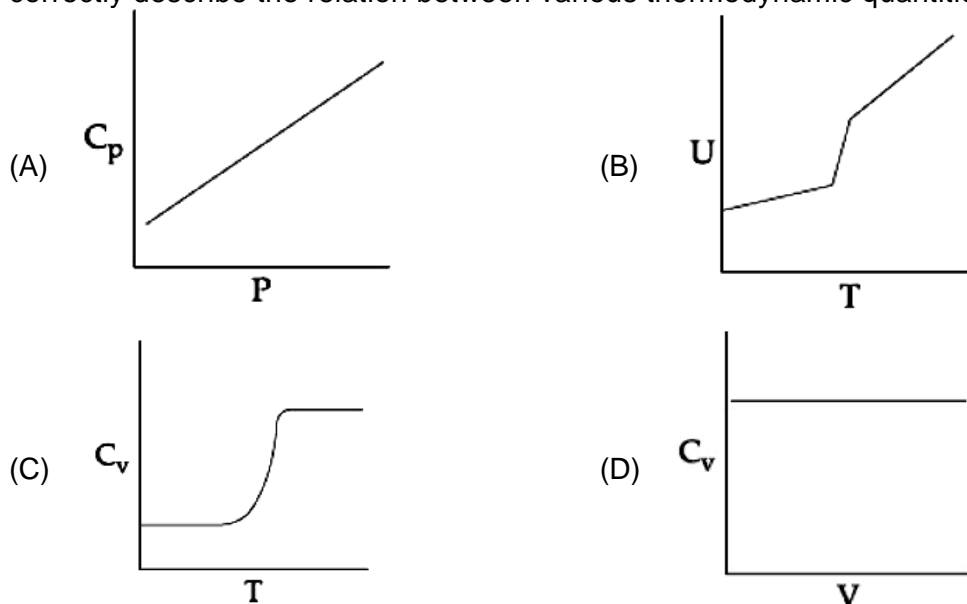

41. Among the following compounds most basic amino acid is
 (A) Asparagine (B) Lysine
 (C) Serine (D) Histidine
42. The increasing order of reactivity of the following compounds towards reaction with alkyl halide directly is:

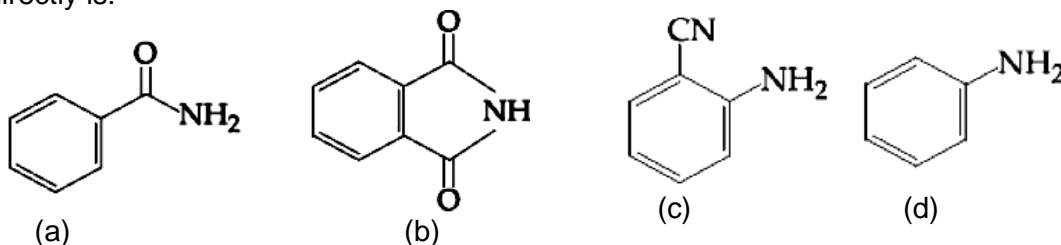

- (A) $(b) < (a) < (c) < (d)$ (B) $(a) < (b) < (c) < (d)$
 (C) $(b) < (a) < (d) < (c)$ (D) $(a) < (c) < (d) < (b)$

43. Which of the following has lowest freezing point?

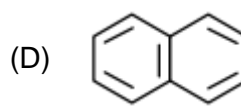
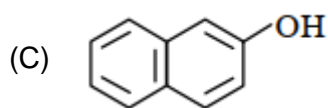
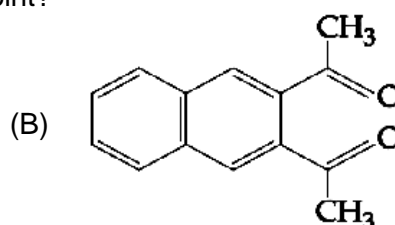
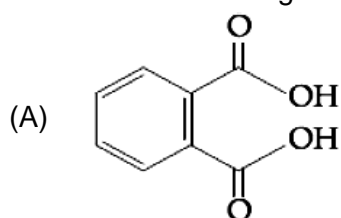

44. 50 mL of 0.5 M oxalic acid is needed to neutralize 25 ml of sodium hydroxide solution. The amount of NaOH in 50 mL of the given sodium hydroxide solution is

(A) 40 g (B) 10 g
(C) 20 g (D) 80 g

45. The volume of gas A has is twice than that of gas B. The compressibility factor of gas A is thrice that that of gas B at same temperature. The pressure of gases for equal per moles are

(A) $3P_A = 2P_B$ (B) $2P_A = 3P_B$
(C) $P_A = 3P_B$ (D) $P_A = 2P_B$

46. The hardness of water sample (in terms of equivalents of CaCO_3) containing 10^{-3} M CaSO_4 is

(molar mass of $\text{CaSO}_4 = 136 \text{ g mol}^{-1}$)

(A) 10 ppm (B) 50 ppm
(C) 90 ppm (D) 100 ppm

- 47.

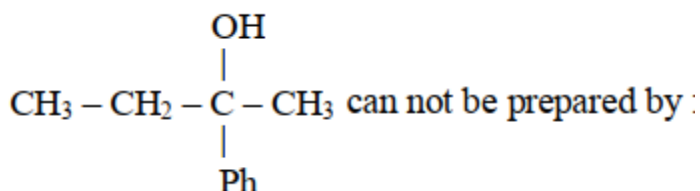

(A) $\text{CH}_3\text{CH}_2\text{COCH}_3 + \text{PhMgX}$ (B) $\text{PhCOCH}_2\text{CH}_3 + \text{CH}_3\text{MgX}$
(C) $\text{PhCOCH}_3 + \text{CH}_3\text{CH}_2\text{MgX}$ (D) $\text{HCHO} + \text{PhCH}(\text{CH}_3)\text{CH}_2\text{MgX}$

48. Freezing point of a 4% aqueous solution of X is equal to freezing point of 12% aqueous solution of Y. If molecular weight of X is A then molecular weight of Y is

(A) 3A (B) 2A
(C) A (D) 4A

49. The metal d-orbital that can directly facing the ligands in $\text{K}_3[\text{Co}(\text{CN})_6]$ are

(A) d_{xy} and $d_{x^2-y^2}$ (B) $d_{x^2-y^2}$ and d_{z^2}
(C) d_{xz} , d_{yz} and d_{z^2} (D) d_{xy} , d_{xz} and d_{yz}

50. Decomposition of X exhibits a rate constant for $0.05 \mu\text{g}/\text{year}$. How many years are required for the decomposition of $5 \mu\text{g}$ of X into $2.5 \mu\text{g}$?

(A) 50 (B) 25
(C) 20 (D) 40

51. The standard electrode potential E^\ominus and its temperature coefficient $\left(\frac{dE^\ominus}{dT}\right)$ for a cell are 2 V and $-5 \times 10^{-4} \text{ VK}^{-1}$ at 300 K respectively. The cell reaction is :

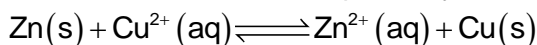

Standard reaction enthalpy ($\Delta_r H^\ominus$).....

- (A) -412.8 (B) -384.0
(C) 1920 (D) 206.4 kJ
52. The major product of the following reaction is

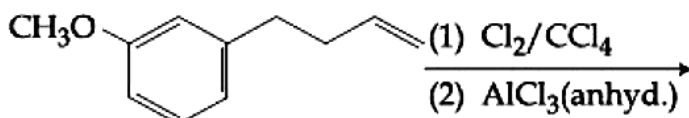

- (A)
- (B)
- (C)
- (D)

53. The element with $Z = 120$ (not yet discovered) will be an/a
(A) Inner transition metal (B) Alkaline earth metal
(C) Alkali metal (D) Transition metal

54. In the following reaction
Aldehyde + Alcohol $\xrightarrow{\text{HCl}}$ Acetal

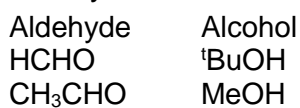

The best combination is

- (A) CH_3CHO and ^tBuOH (B) HCHO and MeOH
(C) CH_3CHO and MeOH (D) HCHO and ^tBuOH
55. Two solids dissociate as follows

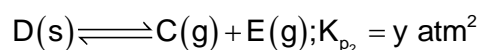
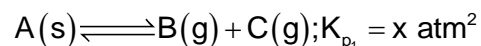

The total pressure when both the solids dissociate simultaneously is

- (A) $\sqrt{x+y}$ atm (B) $2(\sqrt{x+y})$ atm
(C) $(x+y)$ atm (D) $x^2 + y^2$ atm

56. In the following reactions, products A and B are:

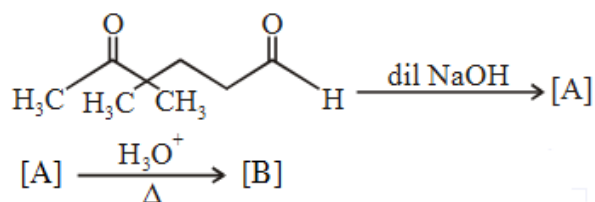

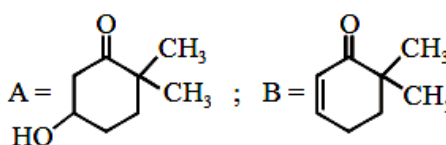
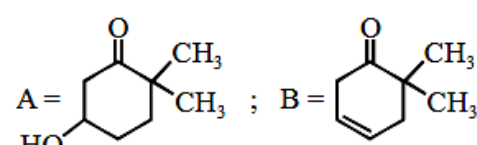
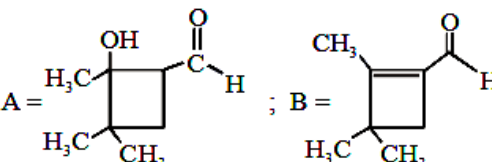
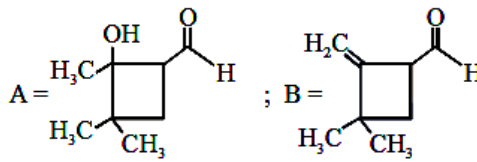
- (A)  ; (B) 
- (C)  ; (D) 

57. What is the work function of the metal if the light of wavelength 4000 \AA generates photoelectrons of velocity $6 \times 10^5 \text{ ms}^{-1}$ from it?
 (Mass of electron = $9 \times 10^{-31} \text{ kg}$
 Velocity of light = $3 \times 10^8 \text{ ms}^{-1}$
 Planck's constant = $6.626 \times 10^{-34} \text{ Js}$
 Charge of electron = $1.6 \times 10^{-19} \text{ JeV}^{-1}$)
 (A) 0.9 eV (B) 3.1 eV
 (C) 2.1 eV (D) 4.0 eV
58. Iodine reacts with concentrated HNO_3 to yield along with other products. The oxidation state of iodine in Y is
 (A) 5 (B) 7
 (C) 3 (D) 1
59. Poly - β -hydroxybutyrate-co- β -hydroxyvalerate(PHBV) is a copolymer of _____
 (A) 3-hydroxybutanoic acid and 4-hydroxypentanoic acid
 (B) 2-hydroxybutanoic acid and 3-hydroxypentanoic acid
 (C) 3-hydroxybutanoic acid and 2-hydroxypentanoic acid
 (D) 3-hydroxy butanoic acid and 3-hydroxypentanoic acid
60. Water sample with BOD vales of 4 ppm and 18 ppm respectively are
 (A) Clean and clean (B) Highly polluted and clean
 (C) Clean and highly polluted (D) Highly polluted and highly polluted.

PART-C (MATHEMATICS)

61. An ordered pair (α, β) for which the system of linear equations
 $(1 + \alpha)x + \beta y + z = 2$
 $\alpha x + (1 + \beta)y + z = 3$
 $\alpha x + \beta y + 2z = 2$
 has a unique solution, is:
 (A) (2, 4) (B) (-3, 1)
 (C) (-4, 2) (D) (1, -3)
62. The product of three consecutive terms of a G.P. is 512. If 4 is added to each of the first and the second of these terms, the three terms now form an A.P. Then the sum of the original three terms of the given G.P. is:
 (A) 36 (B) 32
 (C) 24 (D) 28
63. The Boolean expression $((p \wedge q) \vee (p \vee \sim q)) \wedge (\sim p \wedge \sim q)$ is equivalent to:
 (A) $p \wedge q$ (B) $p \wedge (\sim q)$
 (C) $(\sim p) \wedge (\sim q)$ (D) $p \vee (\sim q)$
64. Consider three boxes, each containing 10 balls labelled 1, 2,, 10. Suppose one ball is randomly drawn from each of the boxes. Denote by n_i , the label of the ball drawn from the i^{th} box, ($i = 1, 2, 3$). Then, the number of ways in which the balls can be chosen such that $n_1 < n_2 < n_3$ is:
 (A) 120 (B) 82
 (C) 240 (D) 164
65. A tetrahedron has vertices $P(1, 2, 1)$, $Q(2, 1, 3)$, $R(-1, 1, 2)$ and $O(0, 0, 0)$. The angle between the faces OPQ and PQR is:
 (A) $\cos^{-1}\left(\frac{17}{31}\right)$ (B) $\cos^{-1}\left(\frac{19}{35}\right)$
 (C) $\cos^{-1}\left(\frac{9}{35}\right)$ (D) $\cos^{-1}\left(\frac{7}{31}\right)$
66. The maximum area (in sq. units) of a rectangle having its base on the x-axis and its other two vertices on the parabola, $y = 12 - x^2$ such that the rectangle lies inside the parabola, is:
 (A) 36 (B) $20\sqrt{2}$
 (C) 32 (D) $18\sqrt{3}$
67. If the straight line, $2x - 3y + 17 = 0$ is perpendicular to the line passing through the points (7, 17) and (15, β), then β equals:
 (A) $\frac{35}{3}$ (B) -5
 (C) $-\frac{35}{3}$ (D) 5
68. The sum of the distinct real values of μ , for which the vectors, $\mu\hat{i} + \hat{j} + \hat{k}$, $\hat{i} + \mu\hat{j} + \hat{k}$, $\hat{i} + \hat{j} + \mu\hat{k}$ are co-planar, is:
 (A) -1 (B) 0
 (C) 1 (D) 2

69. Let P(4, -4) and Q(9, 6) be two points on the parabola, $y^2 = 4x$ and let X be any point on the arc POQ of this parabola, where O is the vertex of this parabola, such that the area of ΔPXQ is maximum. Then this maximum Area (in sq. units) is:
- (A) $\frac{75}{2}$ (B) $\frac{125}{4}$
 (C) $\frac{625}{4}$ (D) $\frac{125}{2}$
70. Let $P = \begin{bmatrix} 1 & 0 & 0 \\ 3 & 1 & 0 \\ 9 & 3 & 1 \end{bmatrix}$ and $Q = [q_{ij}]$ be two 3×3 matrices such that $Q - P^5 = I_3$. Then $\frac{q_{21} + q_{31}}{q_{32}}$ is equal to:
- (A) 10 (B) 135
 (C) 15 (D) 9
71. Let $y = y(x)$ be the solution of the differential equation, $x \frac{dy}{dx} + y = x \log_e x, (x > 1)$. If $2y(2) = \log_e 4 - 1$, then $y(e)$ is equal to:
- (A) $-\frac{e}{2}$ (B) $-\frac{e^2}{2}$
 (C) $\frac{e}{4}$ (D) $\frac{e^2}{4}$
72. The area (in sq. units) of the region bounded by the parabola, $y = x^2 + 2$ and the lines, $y = x + 1, x = 0$ and $x = 3$, is:
- (A) $\frac{15}{4}$ (B) $\frac{21}{2}$
 (C) $\frac{17}{4}$ (D) $\frac{15}{2}$
73. In a random experiment, a fair die is rolled until two fours are obtained in succession. The probability that the experiment will end in the fifth throw of the die is equal to:
- (A) $\frac{200}{6^5}$ (B) $\frac{150}{6^5}$
 (C) $\frac{225}{6^5}$ (D) $\frac{175}{6^5}$
74. Let C_1 and C_2 be the centres of the circles $x^2 + y^2 - 2x - 2y - 2 = 0$ and $x^2 + y^2 - 6x - 6y + 14 = 0$ respectively. If P and Q are the points of intersection of these circles, then the area (in sq. units) of the quadrilateral PC_1QC_2 is:
- (A) 8 (B) 6
 (C) 9 (D) 4
75. The maximum value of $3 \cos \theta + 5 \sin \left(\theta - \frac{\pi}{6} \right)$ for any real value of θ is:
- (A) $\sqrt{19}$ (B) $\frac{\sqrt{79}}{2}$
 (C) $\sqrt{34}$ (D) $\sqrt{31}$
76. Considering only the principal values of inverse functions, the set $A = \left\{ x \geq 0 : \tan^{-1}(2x) + \tan^{-1}(3x) = \frac{\pi}{4} \right\}$
- (A) contains two elements (B) contains more than two elements
 (C) is a singleton (D) is an empty set

77. If λ be the ratio of the roots of the quadratic equation in x , $3m^2x^2 + m(m - 4)x + 2 = 0$, then the least value of m for which $\lambda + \frac{1}{\lambda} = 1$, is:
- (A) $2 - \sqrt{3}$ (B) $4 - 3\sqrt{2}$
 (C) $-2 + \sqrt{2}$ (D) $4 - 2\sqrt{3}$
78. If a variable line, $3x + 4y - \lambda = 0$ is such that the two circles $x^2 + y^2 - 2x - 2y + 1 = 0$ and $x^2 + y^2 - 18x - 2y + 78 = 0$ are on its opposite sides, then the set of all values of λ is the interval:
- (A) (2, 17) (B) [13, 23]
 (C) [12, 21] (D) (23, 31)
79. For $x > 1$, if $(2x)^{2y} = 4e^{2x-2y}$, then $(1 + \log_e 2x)^2 \frac{dy}{dx}$ is equal to:
- (A) $\frac{x \log_e 2x - \log_e 2}{x}$ (B) $\log_e 2x$
 (C) $\frac{x \log_e 2x + \log_e 2}{x}$ (D) $x \log_e 2x$
80. The integral $\int \cos(\log_e x) dx$ is equal to: (where C is a constant of integration)
- (A) $\frac{x}{2} [\sin(\log_e x) - \cos(\log_e x)] + C$ (B) $x [\cos(\log_e x) + \sin(\log_e x)] + C$
 (C) $\frac{x}{2} [\cos(\log_e x) + \sin(\log_e x)] + C$ (D) $x [\cos(\log_e x) - \sin(\log_e x)] + C$
81. A ratio of the 5th term from the beginning to the 5th term from the end in the binomial expansion of $\left(2^{\frac{1}{3}} + \frac{1}{2(3)^{\frac{1}{3}}}\right)$ is:
- (A) $1:2(6)^{\frac{1}{3}}$ (B) $1:4(16)^{\frac{1}{3}}$
 (C) $4(36)^{\frac{1}{3}}:1$ (D) $2(36)^{\frac{1}{3}}:1$
82. Let $S_k = \frac{1+2+3+\dots+k}{k}$. If $S_1^2 + S_2^2 + \dots + S_{10}^2 = \frac{5}{12}A$, then A equal to:
- (A) 283 (B) 301
 (C) 303 (D) 156
83. The perpendicular distance from the origin to the plane containing the two lines, $\frac{x+2}{3} = \frac{y-2}{5} = \frac{z+5}{7}$ and $\frac{x-1}{1} = \frac{y-4}{4} = \frac{z+4}{7}$, is:
- (A) $11\sqrt{6}$ (B) $\frac{11}{\sqrt{6}}$
 (C) 11 (D) $6\sqrt{11}$
84. If the sum of the deviations of 50 observations from 30 is 50, then the mean of these observations is:
- (A) 30 (B) 51
 (C) 50 (D) 31

85. Let S be the set of all points in $(-\pi, \pi)$ at which the function, $f(x) = \min \{\sin x, \cos x\}$ is non-differentiable. Then S is a subset of which of the following?
- (A) $\left\{-\frac{\pi}{4}, 0, \frac{\pi}{4}\right\}$ (B) $\left\{-\frac{3\pi}{4}, -\frac{\pi}{4}, \frac{3\pi}{4}, \frac{\pi}{4}\right\}$
 (C) $\left\{-\frac{\pi}{2}, -\frac{\pi}{4}, \frac{\pi}{4}, \frac{\pi}{2}\right\}$ (D) $\left\{-\frac{3\pi}{4}, -\frac{\pi}{2}, \frac{\pi}{2}, \frac{3\pi}{4}\right\}$
86. Let f and g be continuous functions on $[0, a]$ such that $f(x) = f(a - x)$ and $g(x) + g(a - x) = 4$, then $\int_0^a f(x)g(x)dx$ is equal to:
- (A) $4\int_0^a f(x)dx$ (B) $\int_0^a f(x)dx$
 (C) $2\int_0^a f(x)dx$ (D) $-3\int_0^a f(x)dx$
87. $\lim_{x \rightarrow \pi/4} \frac{\cot^3 x - \tan x}{\cos\left(x + \frac{\pi}{4}\right)}$ is:
- (A) 4 (B) $4\sqrt{2}$
 (C) $8\sqrt{2}$ (D) 8
88. If $\frac{z - \alpha}{z + \alpha}$ ($\alpha \in \mathbb{R}$) is a purely imaginary number and $|z| = 2$, then a value of α is:
- (A) 2 (B) 1
 (C) $\frac{1}{2}$ (D) $\sqrt{2}$
89. Let $S = \{1, 2, 3, \dots, 100\}$. The number of non-empty subsets A of S such that the product of elements in A is even is:
- (A) $2^{100} - 1$ (B) $2^{50} (2^{50} - 1)$
 (C) $2^{50} - 1$ (D) $2^{50} + 1$
90. If the vertices of a hyperbola be at $(-2, 0)$ and $(2, 0)$ and one of its foci be at $(-3, 0)$, then which one of the following points does not lie on this hyperbola?
- (A) $(-6, 2\sqrt{10})$ (B) $(2\sqrt{6}, 5)$
 (C) $(4, \sqrt{15})$ (D) $(6, 5\sqrt{2})$

JEE (Mains) – 2019

ANSWERS

PART A – PHYSICS

1.	Insufficient information	2.	C	3.	C
4.	C	5.	A	6.	A
8.	D	9.	C	10.	C
12.	D	13.	A	14.	D
16.	C	17.	C	18.	D
20.	C	21.	C	22.	A
24.	B	25.	D	26.	B
28.	B	29.	C	30.	C

PART B – CHEMISTRY

31.	B	32.	D	33.	A	34.	A
35.	A	36.	C	37.	B	38.	D
39.	A	40.	A	41.	B	42.	A
43.	D	44.	Bonus	45.	B	46.	D
47.	A	48.	A	49.	B	50.	A
51.	A	52.	A	53.	B	54.	B
55.	C	56.	A	57.	C	58.	A
59.	D	60.	C				

PART C – MATHEMATICS

61.	A	62.	D	63.	C	64.	A
65.	B	66.	C	67.	D	68.	A
69.	B	70.	A	71.	C	72.	D
73.	D	74.	D	75.	A	76.	C
77.	B	78.	C	79.	A	80.	C
81.	C	82.	C	83.	B	84.	D
85.	B	86.	C	87.	D	88.	A
89.	B	90.	D				

HINTS AND SOLUTIONS

PART A – PHYSICS

1. Cannot determine, degree of freedom must be given.

2. $y = 10^{-3} \sin(50t + 2x)$
Wave is travelling along negative x-axis

$$\text{Wave speed} = \frac{\omega}{k} = \frac{50}{2} = 25 \text{ m/s.}$$

3.

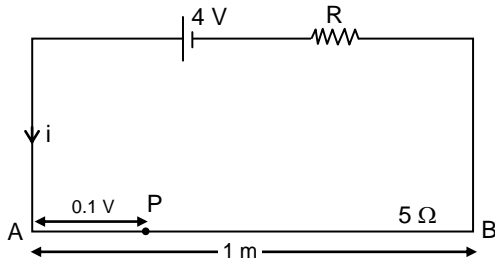

$$i = \frac{4}{5 + R}$$

$$V_{AB} = i(5) = \frac{20}{5 + R}$$

$$V_{AP} = \frac{V_{AB}}{L} (0.1) = \frac{20}{5 + R} \left(\frac{0.1}{1} \right) = \frac{2}{5 + R}$$

$$\text{Now, } \frac{2}{5 + R} = 5 \times 10^{-3}$$

$$\Rightarrow R = 395 \Omega$$

4. $\frac{dR}{d\ell} = \frac{k}{\sqrt{\ell}}$ $k = \text{constant}$

$$\int_0^R dR = k \int_0^1 \frac{d\ell}{\sqrt{\ell}}$$

$R = 2k$ resistance of wire AB.

$$\text{Again, } \int_0^{R/2} dR = k \int_0^L \frac{d\ell}{\sqrt{\ell}} \quad L \rightarrow \text{Length AP}$$

$$\frac{R}{2} = k2 L^{1/2} \quad ; \quad k = k2 L^{1/2}$$

$$\Rightarrow L = \frac{1}{4} \text{ m} = 0.25 \text{ m}$$

5.

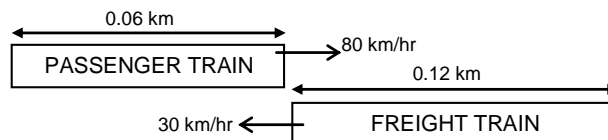

Time taken if both moving in same direction

$$t_1 = \frac{\text{distance}}{\text{speed}} = \frac{0.12 + 0.06}{80 - 30} = \frac{0.18}{50}$$

Time taken if moving in opposite direction.

$$t_2 = \frac{\text{distance}}{\text{speed}} = \frac{0.12 + 0.06}{80 + 30} = \frac{0.18}{110}$$

$$\frac{t_1}{t_2} = \frac{11}{5}$$

6.

Resistance, $R = \frac{V^2}{P}$

$$\Rightarrow R_1 = \frac{(220)^2}{25} = 1936 \Omega$$

$$R_2 = \frac{(220)^2}{100} = 484 \Omega$$

$$i = \frac{220}{R_1 + R_2} = \frac{1}{11} \text{ A}$$

Power dissipated through $R_1 = P_1 = i^2 R_1 = 16 \text{ W}$

Power dissipated through $R_2 = P_2 = i^2 R_2 = 4 \text{ W}$

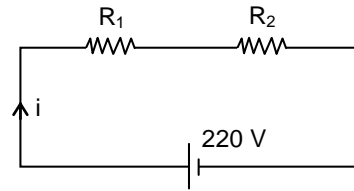

7.

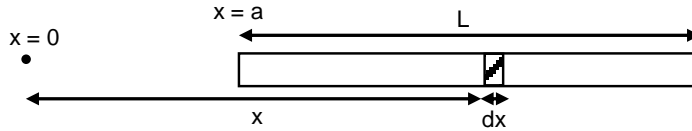

Mass of element = $dm = (A + Bx^2)dx$

Field due to element at $x = 0$

$$dE = \frac{G(dm)}{x^2} = \left(\frac{GA}{x^2} + GB \right) dx$$

Total field

$$E = GA \int_a^{a+L} \frac{1}{x^2} dx + GB \int_a^{a+L} dx$$

$$= G \left[A \left(\frac{1}{a} - \frac{1}{a+L} \right) + BL \right]$$

So, force = mE

$$= Gm \left[A \left(\frac{1}{a} - \frac{1}{a+L} \right) + BL \right]$$

8.

Image by convex lens:

$$\frac{1}{v} - \frac{1}{u} = \frac{1}{f} \quad ; \quad \frac{1}{v} + \frac{1}{20} = \frac{1}{5}$$

$$v = \frac{20}{3} \text{ cm}$$

Image by concave lens:

$$u = \left[\frac{20}{3} - 2 \right] = \frac{14}{3} \text{ cm}$$

$$\frac{1}{v} - \frac{1}{u} = \frac{1}{f} \quad ; \quad \frac{1}{v} - \frac{3}{14} = -\frac{1}{5}$$

$$v = 70 \text{ cm}$$

9.

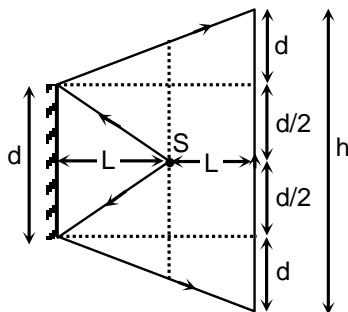

$$h = d + \frac{d}{2} + \frac{d}{2} + d = 3d.$$

10. $I = \frac{1}{2} \epsilon_0 E_0^2 C \quad \dots(i)$

$0.96 I = \frac{1}{2} E_0^2 V \quad \dots(ii)$

$\Rightarrow 0.96 = \left(\frac{E'_0}{E_0}\right)^2 \frac{\epsilon}{\epsilon_0} \frac{v}{C}$

$0.96 = \left(\frac{E'_0}{E_0}\right)^2 \frac{\epsilon}{\epsilon_0} \frac{1}{1.5}$

$0.96 = \left(\frac{E'_0}{E_0}\right)^2 \epsilon_r \frac{1}{1.5} \quad \dots(iii)$

and $v = \frac{1}{\sqrt{\mu_0 \epsilon_0 \mu_r \epsilon_r}} ; v = \frac{C}{\sqrt{\mu_r \epsilon_r}}$

$\sqrt{\mu_r \epsilon_r} = \frac{C}{v} ; \sqrt{\epsilon_r} = 1.5 ; \mu_r \approx 1$ for transparent medium.

From equation (iii)

$0.96 = \left(\frac{E'_0}{E_0}\right)^2 (1.5)^2 \left(\frac{1}{1.5}\right)$

$\Rightarrow E'_0 = 24 \text{ V/m}$

11. Work done = Area of loop
 $= \frac{1}{2} (4) (5) = 10 \text{ J}$

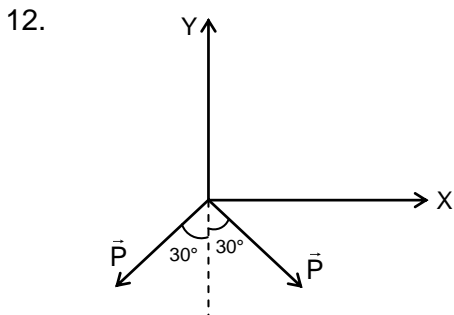

$|\vec{P}| = qL$
 $\vec{P}_{\text{net}} = 2P \cos 30^\circ (-\hat{j})$
 $= P\sqrt{3} (-\hat{j})$
 $= \sqrt{3} qL (-\hat{j})$

13. Three parts of rod can be considered as point masses.

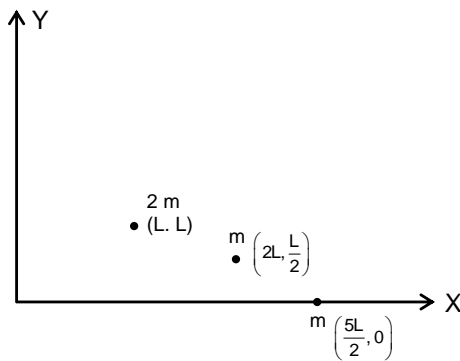

$\vec{r}_{\text{cm}} = \frac{2m \vec{r}_1 + m \vec{r}_2 + m \vec{r}_3}{4m}$

$$\begin{aligned} \vec{r}_{cm} &= \frac{2m(L\hat{i} + L\hat{j}) + m\left(2L\hat{i} + \frac{L}{2}\hat{j}\right) + m\left(\frac{5L}{2}\hat{i}\right)}{4m} \\ &= \frac{\frac{13}{2}L\hat{i} + \frac{5}{2}L\hat{j}}{4} \\ &= \frac{13}{8}L\hat{i} + \frac{5}{8}L\hat{j} \end{aligned}$$

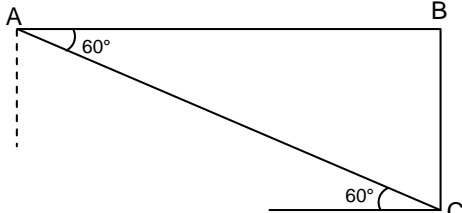
14.  $V_P \rightarrow$ Speed of plane
 $V \rightarrow$ Speed of sound
 $V \cos 60^\circ = V_P$
 $V_P = \frac{V}{2}$

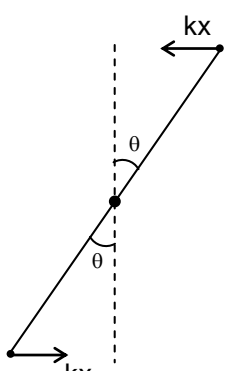
15.  Torque on rod at displacement θ from mean position θ is very small.
 $x = \frac{L}{2}\theta$
 $\tau = 2kx \frac{L}{2} = 2k \frac{L^2}{4}\theta = \frac{kL^2}{2}\theta$
 Now, $\tau = I\alpha$
 $\frac{kL^2}{2}\theta = \frac{mL^2}{12}\alpha$; $\alpha = \frac{6k}{m}\theta$
 $\tau = \frac{\omega}{2\pi} = \frac{1}{2\pi} \sqrt{\frac{6k}{m}}$

16. Just before collision speed of m

$$v = \sqrt{2gL(1 - \cos \theta_0)}$$

Just after collision speed of M

$$v_1 = \sqrt{2gL(1 - \cos \theta_1)}$$

And $v_1 = \left(\frac{M-m}{M+m}\right)v$; $\frac{v_1}{v} = \frac{M-m}{M+m}$

$$\frac{\sqrt{1 - \cos \theta_1}}{\sqrt{1 - \cos \theta_0}} = \frac{M-m}{M+m}$$

$$\frac{\sin(\theta_1/2)}{\sin(\theta_0/2)} = \frac{M-m}{M+m} \quad \left[\because 1 - \cos 2\theta = 2 \sin^2 \theta \right]$$

$$\frac{\theta_1}{\theta_0} = \frac{M-m}{M+m}$$

$$M\theta_1 + m\theta_1 = M\theta_0 - m\theta_0$$

$$M = m \left[\frac{\theta_1 + \theta_0}{\theta_0 - \theta_1} \right]$$

17. $A_C = 100$
 $A_C + A_m = 160$
 $A_C - A_m = 40$

$$A_C = 100, A_m = 60$$

$$\mu = \frac{A_m}{A_C} = 0.6$$

18. Equivalent thermal resistance,

$$\frac{1}{R} = \frac{1}{R_1} + \frac{1}{R_2}$$

$$\frac{k\pi(2R)^2}{L} = \frac{k_1\pi R^2}{L} + \frac{k_2\pi[(2R)^2 - R^2]}{L}$$

$$\Rightarrow 4k = k_1 + 3k_2$$

$$\Rightarrow k = \frac{k_1 + 3k_2}{4}$$

19. Least count = $\frac{\text{Pitch}}{\text{No. of divisions on circular scale}}$

$$5 \times 10^{-6} = \frac{10^{-3}}{N}$$

$$N = 200$$

20. $Y = A.\overline{AB} + AB.\overline{B}$
 $= A.(\overline{A} + \overline{B}) + (AB).\overline{B}$
 $= A\overline{B} + 0$

21. $B = 2 \left[\frac{\mu_0 i}{4\pi d} (\cos \theta_1 - \cos \theta_2) \right]$

$$B = 10^{-4} \quad \theta_1 = 90^\circ$$

$$\mu_0 = 4\pi \times 10^{-7} \quad \theta_2 = 180^\circ$$

$$d = 4 \times 10^{-2}$$

$$\Rightarrow i = 20 \text{ A (into the page)}$$

22. $U = \frac{1}{2} kr^2$

$$\text{Force, } F = -\frac{dU}{dr} = -kr$$

$$\text{For circular motion } \frac{mv^2}{r} = kr \quad \dots(i)$$

$$\text{And } mvr = \frac{nh}{2\pi} \quad \dots(ii)$$

$$\Rightarrow r^2 = \frac{nh}{2\pi\sqrt{km}}$$

$$\Rightarrow r \propto \sqrt{n}$$

$$\text{Total energy, } E = k + U$$

$$= \frac{1}{2} mv^2 + \frac{1}{2} kr^2$$

$$= \frac{1}{2}kr^2 + \frac{1}{2}kr^2 \quad [\text{From equation (i)}]$$

$$E = kr^2$$

$$\Rightarrow E \propto n$$

23. $m_p = m$ $q_p = q$ $k_p = qV = k$
 $m_\alpha = 4m$ $q_\alpha = 2q$ $k_\alpha = 2qV = 2k$

Radius of circular path,

$$r = \frac{mv}{qB} = \frac{\sqrt{2km}}{qB}$$

$$\Rightarrow \frac{r_p}{r_\alpha} = \frac{1}{\sqrt{2}}$$

24.

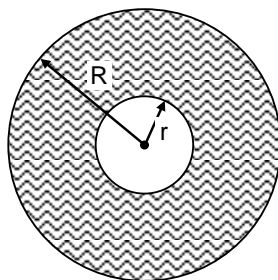

$r = 10 \text{ cm}$ mass per unit area
 $R = 20 \text{ cm}$ area
 Mass = m $\sigma = \frac{m}{\pi(R^2 - r^2)}$

Consider an element of radius x and thickness dx

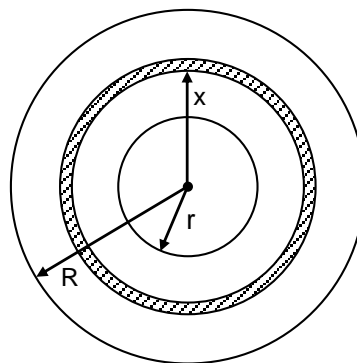

Mass of element $dm = \sigma 2\pi x(dx)$

Moment of inertia of element, $dl = (dm)x^2$

$$\Rightarrow I = \sigma 2\pi \int_r^R x^3 dx$$

$$= \sigma \frac{2\pi}{4} (R^4 - r^4)$$

$$= \frac{m}{\pi(R^2 - r^2)} \frac{\pi}{2} (R^4 - r^4)$$

$$I = \frac{m}{2} (R^2 + r^2) \quad \dots(i)$$

Moment of inertia of thin cylinder of same mass,

$$I = mr_o^2 \quad \dots(ii)$$

$$\Rightarrow mr_o^2 = \frac{m}{2} (R^2 + r^2)$$

$$r_o^2 = 250 \quad ; \quad r_o \approx 16 \text{ cm.}$$

25. After long time, inductor will behave like resistance less wire,

$$i = \frac{15}{R_{eq}} = \frac{15}{(5/2)} = 6 \text{ A}$$

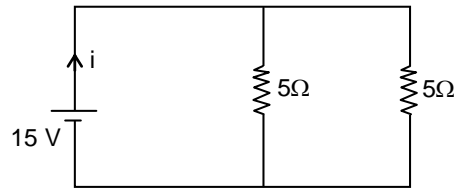

26. Before switch is shifted:

Energy stored,

$$U_i = \frac{1}{2} CE^2$$

and charge stored,
 $Q = CE$

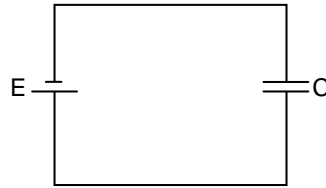

After switch is shifted:

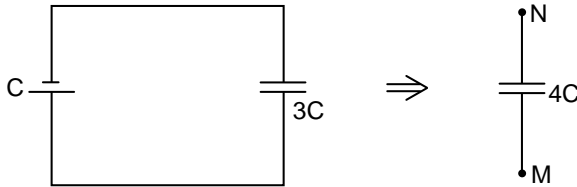

$$V_M - V_N = \frac{Q}{4C} = \frac{CE}{4C} = \frac{E}{4}$$

$$\text{Energy stored, } U_f = \frac{1}{2} (4C) \left(\frac{E}{4} \right)^2 = \frac{1}{8} CE^2$$

$$\text{Energy dissipated} = U_i - U_f = \frac{3}{8} CE^2$$

- 27.

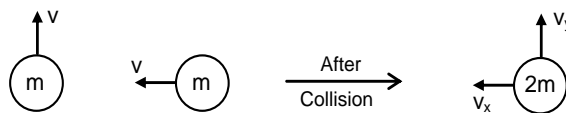

$$2mv_x = mv$$

$$\Rightarrow v_x = \frac{v}{2}$$

$$v_y = \frac{v}{2}$$

$$v_{net} = \sqrt{v_x^2 + v_y^2} = \frac{v}{\sqrt{2}}$$

So, path will be elliptical.

28. When K_1 closed and K_2 is open

$$i = \frac{V}{220 + R} \quad \dots(i)$$

When k_1 and k_2 are closed.

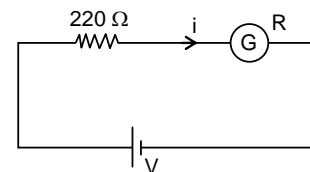

KVL \rightarrow

$$\left(\frac{iR}{25} + \frac{i}{5} \right) 220 + \frac{i}{5} R = V$$

$$\left(\frac{iR}{25} + \frac{i}{5} \right) 220 + \frac{i}{5} R = i(220 + R) \quad \text{From eq. (i)}$$

$$\Rightarrow R = 22 \Omega$$

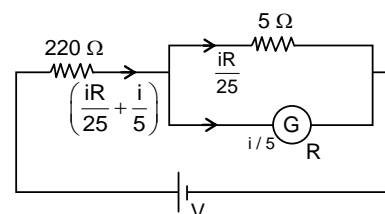

$$29. \quad \lambda = \frac{h}{\sqrt{2mqV}}$$
$$\frac{\lambda_p}{\lambda_\alpha} = \sqrt{\frac{4 \times 1 \times 2500}{1 \times 1 \times 50}} = 10\sqrt{2} = 14.14$$

$$30. \quad U_i + K_i = U_f + K_f$$
$$\frac{kQ^2}{2R_0} + 0 = \frac{kQ^2}{2R} + \frac{1}{2}mv^2$$
$$V = \sqrt{\frac{kQ^2}{m} \left(\frac{1}{R_0} - \frac{1}{R} \right)}$$

PART B – CHEMISTRY

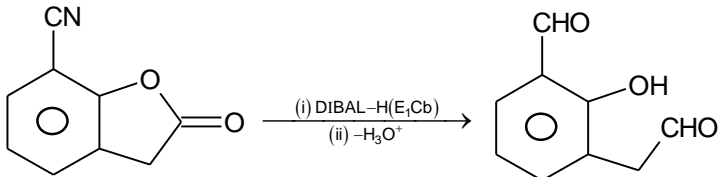
31. Cathode is made up of carbon.
32. Acidic strength \propto Stability of conjugate base
E.N. \rightarrow sp carbon $>$ sp^2 carbon $>$ sp^3 carbon
33. $A + 2B \rightleftharpoons 2C + D$
Initially conc. a $1.5a$
at eq. $a-x$ $1.5(a-2x)$ $2x$ x
at equilibrium $a-x = 1.5a - 2x$
 $0.5a = x$
 $a = 2x$
$$K_c = \frac{(2x)^2 x}{(a-x)(1.5a-2x)^2} = \frac{4x^2 \cdot x}{(x)(x)^2} = 4$$
34. Amount of gas adsorbed $\propto T_c$
35. Organometallic compound contains at least one chemical bond between carbon and a metal.
36. 
- Nitriles are selectively reduced by DIBAL-H to imines followed by hydrolysis to aldehydes similarly, esters are also reduced to aldehyde with DIBAL-H.
37. Rb form super oxides on reaction with excess air
 $Rb + O_2 \rightarrow RbO_2$
 $2RbO_2 + H_2O \rightarrow 2RbOH + H_2O_2 + O_2 \uparrow$
38. Photochemical smog is produced when ultraviolet light from sun reacts with oxides of nitrogen in atmosphere.
39. H_2O is weak field ligand and magnetic moment = Moment = $\sqrt{n(n+2)}BM$
Solving for 'n' we get it as 3; i.e., no. of unpaired electron = 3
 $Fe^{2+} = t_{2g}^4 e_g^2$
 $Co^{2+} = t_{2g}^5 e_g^2$
 $V^{2+} = t_{2g}^3 e_g^0$
 $\therefore M$ is V, Co
40. C_p does not change with change in pressure
41. Compound PI value
Histidine 7.6
Serine 5.7
Lysine 9.8
Asparagine 5.4
42. Lone pair over nitrogen will act as the reacting centre. So, more nucleophilic nitrogen will be more reactive towards alkyl halide.
43. Stronger intermolecular forces result in higher melting point.

44. Eq. of $(\text{COOH})_2 = \text{Eq. of NaOH}$
 $50 \times 0.5 \times 2 = 25 \times M \times 1$
 Mass of NaOH in 50 mL = $\frac{50 \times 2}{1000} \times 40 = 4 \text{ g}$
45. $Z = PV/nRT$
 $P = \frac{ZnRT}{V}$
 at constant T and mol $P \propto \frac{Z}{V}$
 $\frac{P_A}{P_B} = \frac{Z_A}{Z_B} \times \frac{V_B}{V_A} = \left(\frac{3}{1}\right) \times \left(\frac{1}{2}\right) = \frac{3}{2}$
 $\therefore 2P_A = 3P_B$
46. As 1L solution have $10^{-3} \text{ mol CaSO}_4$
 Eq. of $\text{CaSO}_4 = \text{eq. of CaCO}_3$
 In 1L solution
 $n_{\text{CaSO}_4} \times \text{v.f.} = n_{\text{CaCO}_3} \times \text{v.f.}$
 $10^{-3} \times 2 = n_{\text{CaCO}_3} \times 2$
 $n_{\text{CaCO}_3} = 10^{-3} \text{ mol in 1 L}$
 $\therefore w_{\text{CaCO}_3} = 100 \times 10^{-3} \text{ g in 1 L solution}$
 $\therefore \text{hardness in terms of CaCO}_3$
 $= \frac{w_{\text{CaCO}_3}}{w_{\text{Total}}} \times 10^6 = \frac{100 \times 10^{-3} \text{ g}}{1000 \text{ g}} \times 10^6 = 100 \text{ ppm}$
47. The reaction in option (A) will yield 1° -alcohol.
48. $(\Delta T_f)_X = (\Delta T_f)_Y$
 $k_f m_X = k_f m_Y$
 $\frac{4 \times 1000}{A \times 96} = \frac{12 \times 1000}{M \times 88}$
 $M = 3.27 A = 3A$
49. Given $\text{K}_3[\text{Co}(\text{CN})_6]$ is inner orbital complex with hybridization d^2sp^3 and octahedral geometry. Ligands are approaching metal along the axes. Hence, $d_{x^2-y^2}$, d_{z^2} orbitals are directly in front of the ligands.
50. According to unit of rate constant it is a zero order reaction then half life of reaction will be
 $t_{1/2} = \frac{C_0}{2k} = \frac{5 \mu\text{g}}{2 \times 0.05 \mu\text{g/year}} = 50 \text{ years}$
51. $\Delta G = -nFE_{\text{cell}} = -2 \times 96500 \times 2 = -386 \text{ kJ}$
 $\Delta S = nF \left(\frac{dE}{dT} \right) = 2 \times 96500 \times (-5 \times 10^{-4} \text{ J/}^\circ\text{C}) = -96.5 \text{ kJ}$
 at 298 K
 $T\Delta S = 298 \times (-96.5 \text{ J}) = -28.8 \text{ kJ}$
 at constant T (=248 K) and pressure
 $\Delta G = \Delta H - T\Delta S$
 $\Delta H = \Delta G + T\Delta S$
 $= -386 - 28.8 = -412.8 \text{ kJ}$

52.

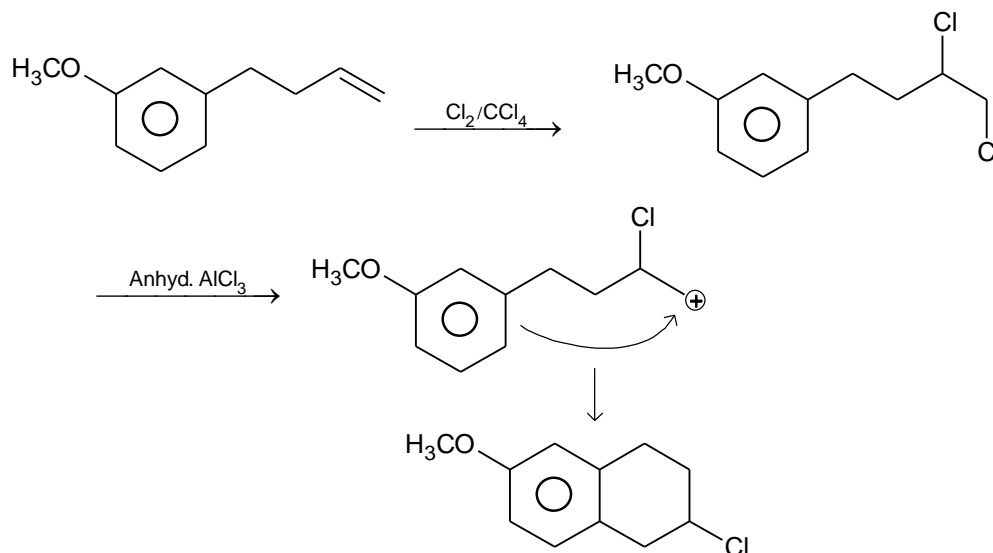

53. $[\text{Og}_{118}] 8s^2$ is configuration for $Z = 120$, where Og is oganesson
As per the configuration it is in IInd group.

54. $\text{Rate} \propto \frac{1}{\text{Steric Crowding}}$

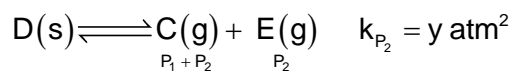
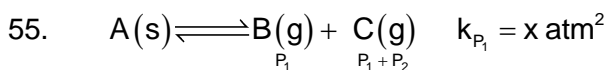

$k_{P_1} = P_1(P_1 + P_2)$

$k_{P_2} = P_2(P_1 + P_2)$

$k_{P_1} + k_{P_2} = (P_1 + P_2)^2$

$x + y (P_1 + P_2)^2$

$P_1 + P_2 = \sqrt{x + y}$

$2(P_1 + P_2) = \sqrt{x + y}$

$P_{\text{Total}} = P_B + P_C + P_E = 2(P_1 + P_2) = 2\sqrt{x + y}$

56.

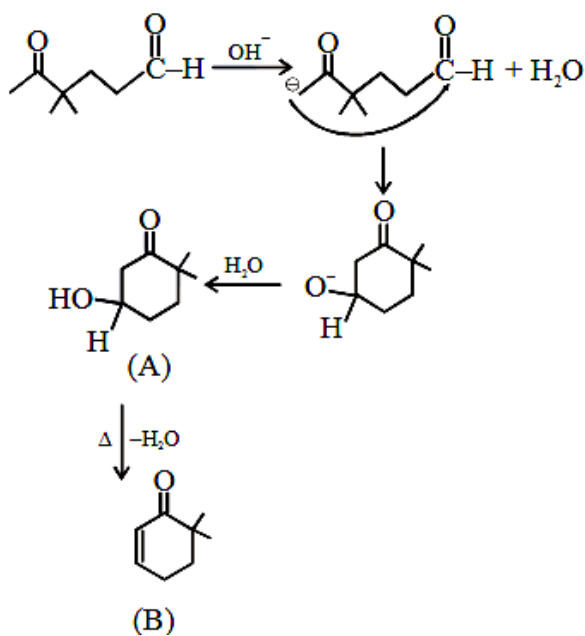

57. $h\nu = \phi + h\nu^{\circ}$

$$\frac{1}{2}mv^2 = hc\left(\frac{1}{\lambda} - \frac{1}{\lambda_0}\right)$$

$$h\nu = \phi + \frac{1}{2}mv^2$$

$$\phi = \frac{6.626 \times 10^{-34} \times 3 \times 10^8}{4000 \times 10^{-10}} - \frac{1}{2} \times 9 \times 10^{-31} \times (6 \times 10^5)^2$$

$$\phi = 3.35 \times 10^{-19} \text{ J} \Rightarrow \phi \simeq 2.1 \text{ eV}$$

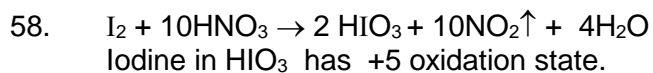

59. PHBV is obtained by copolymerization of 3-Hydroxybutanoic acid & 3-Hydroxypentanoic acid.

60. Clean water has BOD value of less than 5 ppm and highly polluted water has a BOD value of 17 ppm or more.

PART C – MATHEMATICS

61. $(1 + \alpha)x + \beta y + z = 0$
 $\alpha x + (1 + \beta)y + z = 0$
 $\alpha x + \beta y + 2z = 0$

$$D = \begin{vmatrix} 1 + \alpha & \beta & 1 \\ \alpha & 1 + \beta & 1 \\ \alpha & \beta & 2 \end{vmatrix}$$

$$C_1 \rightarrow C_1 + C_2 + C_3$$

$$D = (\alpha + \beta + 2) \begin{vmatrix} 1 & \beta & 1 \\ 1 & 1 + \beta & 1 \\ 1 & \beta & 2 \end{vmatrix}$$

$$R_2 \rightarrow R_2 - R_1, R_3 \rightarrow R_3 - R_1$$

$$D = (\alpha + \beta + 2) \begin{vmatrix} 1 & \beta & 1 \\ 0 & 1 & 0 \\ 0 & 0 & 1 \end{vmatrix} = \alpha + \beta + 2$$

For unique solution $\alpha + \beta + 2 \neq 0 \Rightarrow \alpha + \beta \neq -2$

62. Let the numbers be $\frac{a}{r}, a, ar$

Given $a^3 = 512 \Rightarrow a = 8$

Now given $\frac{8}{r} + 4, 12, 8r$ are in A.P.

$$\Rightarrow 2r^2 - 5r + 2 = 0$$

$$\Rightarrow r = \frac{1}{2} \text{ or } 2$$

Numbers are 4, 8, 16 or 16, 8, 4

Sum of numbers = $4 + 8 + 16 = 28$

63. $(\{(p \wedge q) \vee p\} \vee \{(p \wedge q) \vee \sim q\}) \wedge \sim (p \vee q) \equiv \{p \vee (p \vee \sim q) \wedge (q \vee \sim q)\} \wedge \sim (p \vee q)$
 $(p \vee \{p \vee \sim q\}) \wedge \sim (p \vee q) \equiv (p \vee \sim q) \wedge \sim (p \vee q) \equiv \sim p \wedge \sim q$

64. ${}^{10}C_3 = 120$

65. Vector perpendicular to face OAB

$$= \begin{vmatrix} \hat{i} & \hat{j} & \hat{k} \\ 1 & 2 & 1 \\ 2 & 1 & 3 \end{vmatrix} = 5\hat{i} - \hat{j} - 3\hat{k}$$

Vector perpendicular to face

$$ABC = \begin{vmatrix} \hat{i} & \hat{j} & \hat{k} \\ 2 & 1 & -1 \\ 1 & -1 & 2 \end{vmatrix} = \hat{i} - 5\hat{j} - 3\hat{k}$$

Angle between two faces $\cos \theta = \frac{5 + 5 + 9}{\sqrt{35}\sqrt{35}} = \frac{19}{35}$

$$\Rightarrow \theta = \cos^{-1}\left(\frac{19}{35}\right)$$

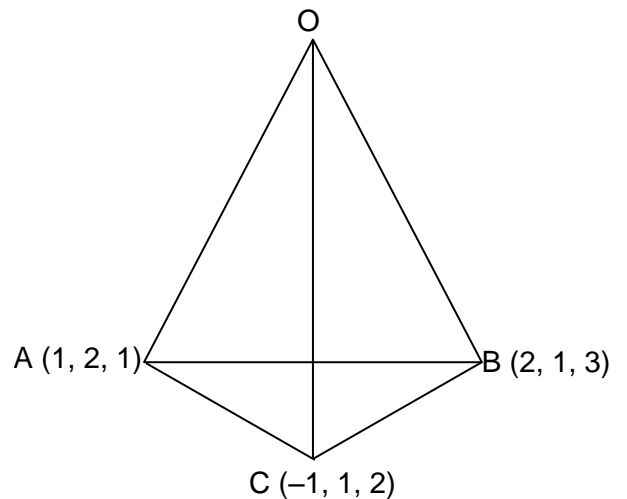

66. $A = 2\alpha(12 - \alpha^2)$

$$\frac{dA}{d\alpha} = 0 \Rightarrow 2(12 - 3\alpha^2) = 0 \Rightarrow \alpha = \pm 2$$

$$A = 4(12 - 4) = 32$$

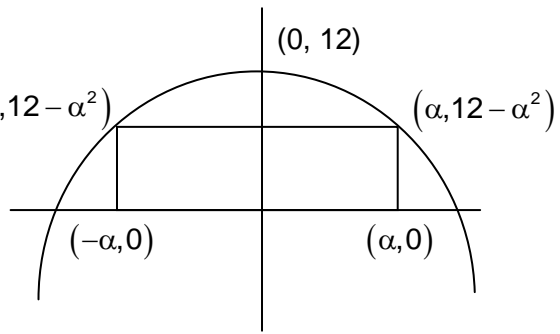

67. Line perpendicular to $2x - 3y + 5 = 0$ is $3x + 2y + c = 0$

Which is satisfied by point (7, 17)

$$\Rightarrow 3(7) + 2(17) + c = 0$$

$$\Rightarrow c = -55$$

$$\Rightarrow \text{equation of line is } 3x + 2y - 55 = 0$$

$$\Rightarrow 3(15) + 2(\beta) - 55 = 0$$

$$\Rightarrow 2\beta = 55 - 45 \Rightarrow \beta = 5$$

68. $D = \begin{vmatrix} \mu & 1 & 1 \\ 1 & \mu & 1 \\ 1 & 1 & \mu \end{vmatrix}, R_1 \rightarrow R_2 + R_3 (\mu + 2) \begin{vmatrix} 1 & 1 & 1 \\ 1 & \mu & 1 \\ 1 & 1 & \mu \end{vmatrix}$

$$C_3 \rightarrow C_3 - C_1 \text{ and } C_2 \rightarrow C_2 - C_1, (\mu + 2) \begin{vmatrix} 1 & 0 & 0 \\ 1 & \mu - 1 & 0 \\ 1 & 0 & \mu - 1 \end{vmatrix} = (\mu + 2)(\mu - 1)^2 = 0$$

Hence sum of distinct value of $\mu = -2 + 1 = -1$

69. $m_{PQ} = \frac{6 + 4}{9 - 4} = 2$

$$2yy' = 4 \Rightarrow 2y \times 2 = 4 \Rightarrow y = 1, x = \frac{1}{4}, X = \left(\frac{1}{4}, 1\right)$$

(Coordinates of points X for maximum area)

$$\therefore \text{area} = \frac{125}{4} \text{ sq. units.}$$

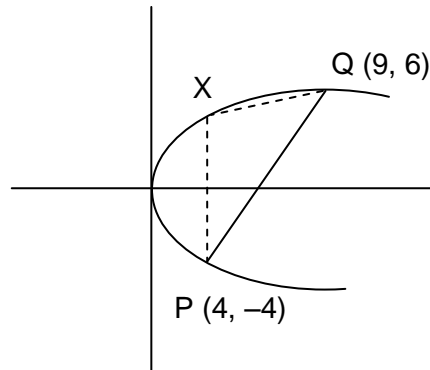

70. $P^2 = \begin{bmatrix} 1 & 0 & 0 \\ 6 & 1 & 0 \\ 27 & 6 & 1 \end{bmatrix} P^3 = \begin{bmatrix} 1 & 0 & 0 \\ 9 & 1 & 0 \\ 54 & 9 & 1 \end{bmatrix} \therefore P^5 = \begin{bmatrix} 1 & 0 & 0 \\ 15 & 1 & 0 \\ 135 & 15 & 1 \end{bmatrix}$

$$Q = \begin{bmatrix} 1 & 0 & 0 \\ 15 & 1 & 0 \\ 135 & 15 & 1 \end{bmatrix} + \begin{bmatrix} 1 & 0 & 0 \\ 0 & 1 & 0 \\ 0 & 0 & 1 \end{bmatrix} = \begin{bmatrix} 2 & 0 & 0 \\ 15 & 2 & 0 \\ 135 & 15 & 2 \end{bmatrix}$$

$$\text{So } \frac{q_{21} + q_{31}}{q_{32}} = \frac{15 + 135}{15} = 10$$

71. $\frac{dy}{dx} + \frac{1}{x}y = \log x$

$$\text{I.F.} = e^{\int \frac{dx}{x}} = x$$

$$yx = \int x \log x \, dx$$

$$xy = \ln x \frac{x^2}{2} - \int \frac{x}{2} dx$$

$$xy = \ln \frac{x^2}{2} - \frac{x^2}{4} + C$$

Putting $x = 2$

$$\frac{\ln 4 - 1}{2} = \ln 2 - \frac{1}{2} + \frac{c}{2}$$

$$c = 0$$

$$y = \frac{x}{2} \ln x - \frac{x}{4}$$

$$y(e) = \frac{e}{2} - \frac{e}{4} = \frac{e}{4}$$

72. Required area

$$\int_0^3 ((x^2 + 2) - (x + 1)) dx = \int_0^3 (x^2 - x + 1) dx = \frac{15}{2}$$

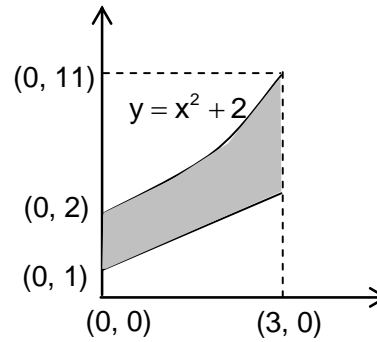

73. $P(\text{---}44)$

$$= P(4\text{---}44) + P(\text{not}4\text{---}44)$$

$$= \frac{1}{6} \times \frac{5}{6} \times \frac{5}{6} \times \frac{1}{6} \times \frac{1}{6} + \frac{5}{6} \times 1 \times \frac{5}{6} \times \frac{1}{6} \times \frac{1}{6} = \frac{25}{6^5} + \frac{25}{6^4} = \frac{175}{6^5}$$

74. Since circles are orthogonal and have equal radii therefore the quadrilateral PC_1QC_2 is a square.
Hence area = $2 \times 2 = 4$ sq. units

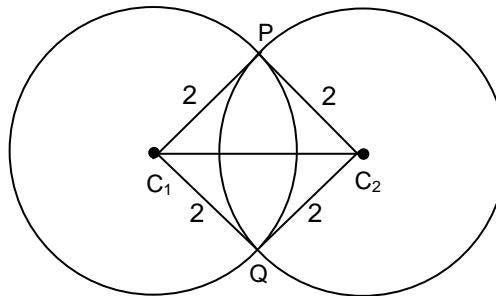

75. $5 \sin\left(\theta - \frac{\pi}{6}\right) + 3 \cos \theta$

$$= 5 \left(\sin \theta \cos \frac{\pi}{6} - \cos \theta \sin \frac{\pi}{6} \right) + 3 \cos \theta$$

$$= \frac{5\sqrt{3}}{2} \sin \theta + \frac{1}{2} \cos \theta$$

Maximum value is $\sqrt{\left(\frac{5\sqrt{3}}{2}\right)^2 + \left(\frac{1}{2}\right)^2} = \sqrt{\frac{76}{4}} = \sqrt{19}$

76. $\tan^{-1} 2x + \tan^{-1} 3x = \frac{\pi}{4}$

Taking tangent on both side, we get $\frac{2x + 3x}{1 - 6x^2} = 1$

$$\Rightarrow 6x^2 + 5x - 1 = 0 \Rightarrow (x + 1)(6x - 1) = 0$$

$$\Rightarrow x = \frac{1}{6} \{-1 \text{ is rejected as it does not satisfies the given equation}\}$$

Hence number of element in S is one.

77. Let roots are α and β now

$$\lambda + \frac{1}{\lambda} = 1 \Rightarrow \frac{\alpha}{\beta} + \frac{\beta}{\alpha} = 1 \Rightarrow \alpha^2 + \beta^2 = \alpha\beta$$

$$(\alpha + \beta)^2 = 2\alpha\beta$$

$$\left(\frac{-m(m-4)}{3m^2}\right)^2 = 3 \cdot \frac{2}{3m^2}$$

$$m^2 - 8m - 2 = 0$$

$$m = 4 \pm 3\sqrt{2}$$

So least value of $m = 4 - 3\sqrt{2}$

78. $3x + 4y - \lambda = 0$

$(7 - \lambda)(31 - \lambda) < 0$ (since centres lie opposite side)

$$\lambda \in (7, 31) \dots\dots\dots(1)$$

$$\left|\frac{7 - \lambda}{5}\right| \geq 1 \text{ and } \left|\frac{31 - \lambda}{5}\right| \geq 2$$

$$|7 - \lambda| \geq 5 \text{ and } |31 - \lambda| \geq 10$$

$$\lambda \leq 2 \text{ or } \lambda \geq 12 \dots\dots\dots(2)$$

$$\text{and } \lambda \leq 21 \text{ or } \lambda \geq 41 \dots\dots\dots(3)$$

$$(1) \cap (2) \cap (3)$$

$$\lambda \in [12, 21]$$

79. $2y \ln 2x = \ln 4 + 2x - 2y$

$$2y(1 + \ln 2x) = \ln 4 + 2x$$

$$y = \frac{\ln 2x - \frac{\ln 2}{x}}{(1 + \ln 2x)^2} \cdot (1 + \ln 2x)^2$$

$$= \ln 2x - \frac{\ln 2}{x} = \frac{x \ln(2x) - \ln 2}{x}$$

80. By parts

$$I = x \cos(\log x) + \int \frac{x}{x} \sin(\log x) dx$$

$$I = x \cos(\log x) + \int \sin(\log x) dx$$

$$I = x \cos(\log x) + \left[x \sin(\log x) - \int \cos \log x dx + c \right]$$

$$I = \frac{x}{2} (\cos(\log x) + \sin(\log x)) + c$$

$$81. \frac{5^{\text{th}} \text{ term from begining}}{5^{\text{th}} \text{ term from end}} = \frac{{}^{10}C_4 \left(\frac{1}{2(3^{1/3})}\right)^4 2^{6/3}}{{}^{10}C_4 (2)^{4/3} \left(\frac{1}{2(3^{1/3})}\right)^6}$$

$$= \frac{2^2 \cdot 2^{-2} \cdot 3^{-4/3}}{2^4 \cdot 2^{(4/3)-6} \cdot 3^{-2}} = 3^{2/3} \cdot 2^{8/3} = 4 \cdot (36)^{1/3}$$

82. $S_k = \frac{k+1}{2}$

$$\sum_{k=1}^{10} \left(\frac{k+1}{2}\right)^2 = \frac{5}{12}A$$

$$2^2 + 3^2 + \dots + 11^2 = \frac{5A}{3}$$

$$\frac{11 \times 12 \times 23}{6} - 1 = \frac{5A}{3}$$

$$505 \times \frac{3}{5} = A$$

$$A = 303$$

83. Equation of plane is $\begin{vmatrix} x+2 & y-2 & z+5 \\ 3 & 5 & 7 \\ 1 & 4 & 7 \end{vmatrix} = 0$

$$\Rightarrow (x+2)7 - (y+2)14 + (z+5)7 = 0$$

$$\Rightarrow x - 2y + z + 11 = 0$$

The perpendicular distance from the origin to the plane is $\left| \frac{0+0+0+11}{\sqrt{1+4+1}} \right| = \frac{11}{\sqrt{6}}$

84. Given $\sum_{i=1}^{50} (x_i - 30) = 50$

$$\Rightarrow \sum x_i = 30(50) + 50 \Rightarrow \frac{\sum x_i}{50} = 31$$

85. Hence number of points where $f(x)$ is non-differentiable are 2

which are $\frac{-3\pi}{4}$ and $\frac{\pi}{4}$

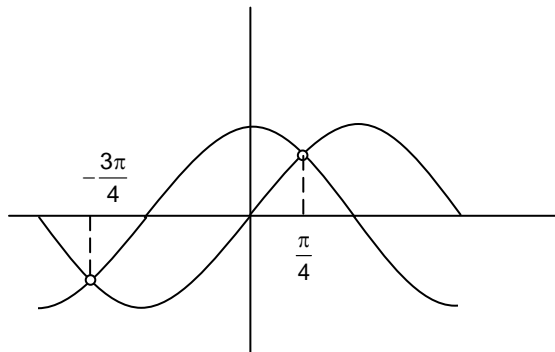

86. $I = \int_0^a f(x)g(x)dx = \int_0^a f(a-x)g(a-x)dx$

$$\left(\because \int_a^b f(x)dx = \int_a^b f(a+b-x)dx \right)$$

$$= \int_0^a f(x)(4-g(x))dx \Rightarrow I = 4 \int_0^a f(x)dx - I \Rightarrow I = 2 \int_0^a f(x)dx$$

87. Using LH rule

$$\lim_{x \rightarrow \frac{\pi}{4}} \frac{3 \cot^2 x (-\operatorname{cosec}^2 x) - \sec^2 x}{-\sin\left(x + \frac{\pi}{4}\right)} = 8$$

88.
$$\frac{z - \alpha}{z + \alpha} = -\left(\frac{\bar{z} - \alpha}{\bar{z} + \alpha}\right)$$

$$z\bar{z} + z\alpha - \alpha\bar{z} - \alpha^2 = -z\bar{z} + \alpha\bar{z} - \alpha\bar{z} + \alpha^2$$

$$\alpha^2 = |z|^2$$

$$\alpha = \pm 2$$

89. Product is even when atleast one element of subset is even
 Hence required number of subsets = total subsets – number of subsets all whose elements are odd
 $= 2^{100} - 2^{50}$

90. Equation of hyperbola is $\frac{x^2}{4} - \frac{y^2}{b^2} = 1$ and $ae = 3$

We know that $a^2e^2 = a^2 + b^2$

$$9 = 4 + b^2 \Rightarrow b^2 = 5$$

Hence equation of hyperbola is $\frac{x^2}{4} - \frac{y^2}{5} = 1$

Hence $(6, 5\sqrt{2})$ does not lie on $\frac{x^2}{4} - \frac{y^2}{5} = 1$

